

DETECT™ Occupancy

Electronic presence detector DETECT O



DETECT O

General

The DETECT O is an electronic presence detector of IR type for use in Swegon's demand controlled ventilation system, for readjusting the room controllers between occupant presence and absence.

Quick facts

- ▶ IR detector of double enclosure type
- ▶ Available for ceiling or wall installation
- ▶ Adjustable for optimal room coverage
- ▶ Changeover normally open and normally closed contacts
- ▶ Adjustable on/off switching delay
- ▶ White enclosure

Technical description

Design

The DETECT O is a presence detector of IR type, i.e. a heat-sensing detector that quickly reacts to human presence in the room. The IR lens has a detection area depending on type, see figures. The detector has connections for normally open (NO) and normally closed contacts (NC) and an adjustable switch on delay (0-10 min.) and switch off delay (0-30 min.). In Swegon's demand controlled ventilation systems, the controller manages the switch off delay, except for when used in combination with ADAPT Damper where the on/off switching delay is set in the DETECT O.

On delivery, the switch on delay is set to 10 seconds. The DETECT O includes a built-in temperature control function that readjusts the presence detector to detect presence if the temperature becomes too high. This function must not be activated in Swegon's demand controlled ventilation system.

Materials and surface treatment

All parts are made of PVC-free plastic, ABS plastic is mainly used.

Maintenance

Dirty products must be cleaned by wiping or vacuum cleaning only.

Declarations

Declaration of construction materials is available for download from www.swegon.com.

Electrical data

Supply voltage	24 V ± 2 V, AC/DC
Power consumption	1 VA
Ambient temperature:	-20° C till +50° C
Degree of protection	IP 20
Max. detection area	15 x 15 m
Max. permissible load on contacts	
DETECT O V110	24V AC/DC 3A
DETECT O T 360	24V AC/DC 0,2A

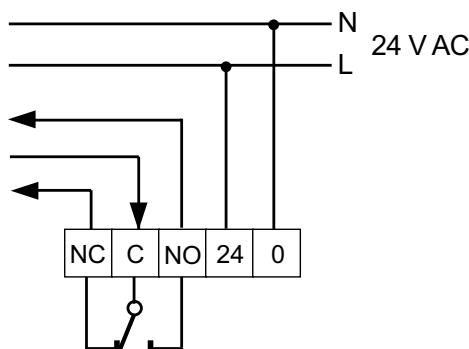

Figure 1. Wiring diagram. NC-C is closed if no occupant is present, NO-C is closed if an occupant is present.

Planning

The presence detector is used for minimising energy consumption in unused areas. Max recommended room area is 100 m². Several occupancy sensors connected in parallel to the room controller are recommended to provide the best operation in large rooms where coverage lies outside the detection area according to Figures 2 and 3. The switching delay should not be used when the DETECT O is used for simultaneous light control. Corner placement of the DETECT O V110 in one corner and for the DETECT O T360 in the centre of the ceiling is recommended.

Detection area

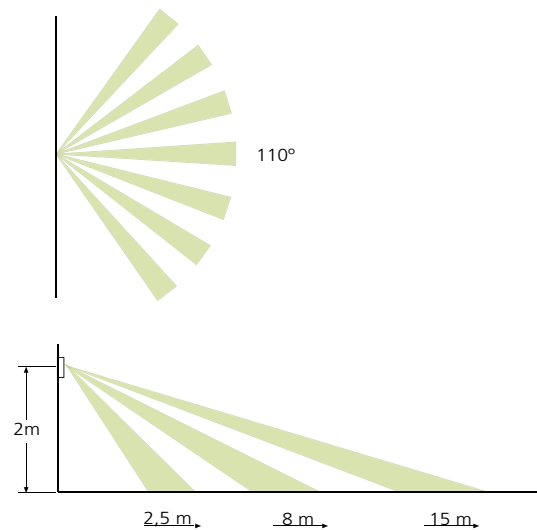

Figure 2. Detection area. Wall mounted DETECT O V110

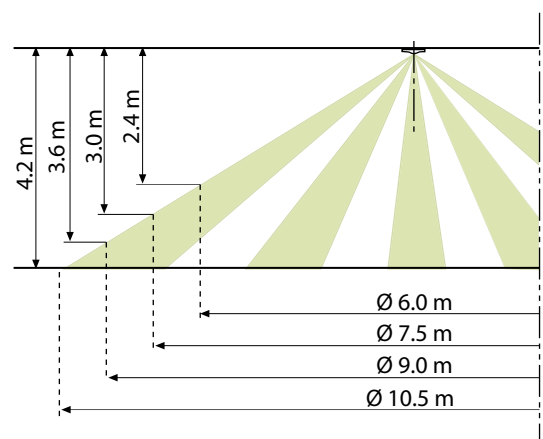

Figure 3. Detection area. Ceiling mounted DETECT O T360.

Installation

The DETECT O can be installed in different places and heights in the room. The presence detector should be placed so that it is not blocked by book shelves or partition walls and must not be exposed to direct sunlight.

Corner placement of the DETECT O V110 at max. 2 m above the floor is recommended to provide the best possible detection. The use of several detectors is recommended in larger rooms.

The DETECT O V110 has a special wall bracket that enables it to be secured to a wall or ceiling. See Figure 5. The presence detector can also be secured to a wall without the wall bracket.

1. Back off the locking screw and lift off the front of the detector housing. Remove the circuit card from the back.
2. Choose wall, corner or ceiling mounting. Then tap out the appropriate knockouts for the screw holes and install the back.
3. Refit the circuit card and connect the cables.
4. Be careful to seal the gap at all the cable lead throughs to prevent insects from entering the detector housing.
5. Refit the front.
6. CAUTION! Always isolate the voltage supply to the detector before changing the switch on and switch off time delays.

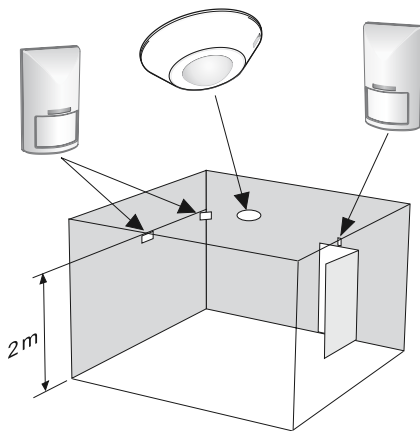

Figure 4. Suitable locations for the DETECT O room unit.

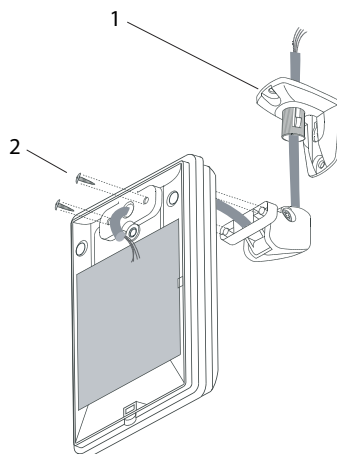

Figure 5. Installation of the DETECT O V110 with supplied mounting bracket (1).

Dimensions

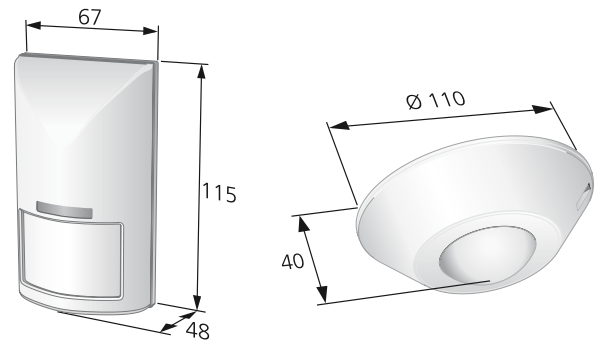

Figure 6. DETECT O V110 and DETECT O T360.

Order key

Product

Presence detector DETECT O a -aaaa

Version:

Type:

Wall mounted: V110

Ceiling mounted: T360

DETECT O

Specification example

GO XX

Swegon's type DETECT Oa electronic presence detector which is included in Swegon's demand controlled ventilation system with the following functions:

- IR-detector of double enclosure type
- Changeover contacts
- Adjustable on/off switching delay

Type: DETECT Oa V110 xx items