

Sizing, Installation, Dimensions and Weight

GOLD SD, size 12

DELIVERY AND TRANSPORT WITHIN THE SITE

The GOLD SD 12 units are available in right-hand or left-hand version as a fan section or a fan section + coil heat exchanger.

The unit is always supplied as one unit. The air handling unit can be split at the building site to facilitate transporting it within the site. The sections are jointed together by means of bolts.

The GOLD SD can be used as a supply air or an return air handling unit. If both supply air and return air handling units are used in a ventilation system, the supply air unit is fitted with a control unit and the return air unit is without. A communication cable is used to connect them to one another making it possible to control both units.

Filter holders for pleated filters are provided inside the fan section. Set of filters with pleated medium, pressure sensor, hoses and communication cable are optional extras.

The air handling unit is delivered on wooden pallets.

DUCT CONNECTION OPTIONS

A: Specify right-hand or left-hand version when ordering!

CLEAR SPACE FOR INSPECTION

A clear space of 36 inches should be provided in front of the unit.

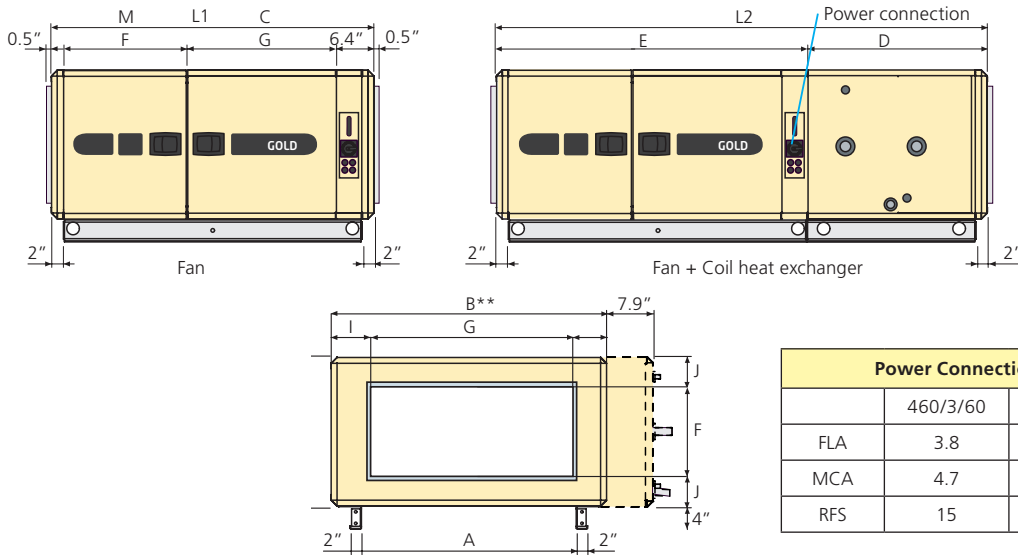
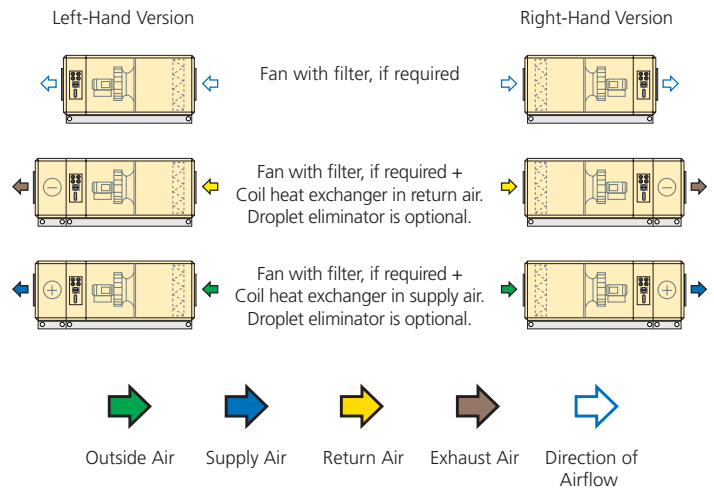

* The air handling unit is supplied without end connection panel if a duct accessory housed in an insulated casing will be connected.

** Width of coil heat exchanger (if required) = B + 7.9 inches.

Size	L1	L2	B	H	A	C	D	E	F	G	I	J	K
SD12	55.3	82.4	47.3	25.5	36.8	25.6	29.2	53.2	18	32	7.6	3.75	21.3

Airflow ERV	Airflow CWC	Fan + Filter Wgt (lbs)	Fan + Filter + Coil Wgt (lbs)
3500 cfm	2480 cfm (based on 550 fpm)	355-415	730-790