

Installation Instructions, TBLZ-1-23-aa Pressure Transducer GOLD/COMPACT/MIRUVENT

1. General

The pressure transducer is designed for use in ventilation systems intended for variable airflow by keeping the pressure constant in the ducting system. The pressure sensor is also used in ventilation systems where it is desirable to achieve a constant airflow (MIRUVENT). The pressure sensor can also be used for the defrosting function for rotary heat exchangers, monitoring pre-filters, monitoring standard filters or for the ReCO₂ function. The pressure sensor is the same as those used for measuring the flows and monitoring the filters in the GOLD and the COMPACT units

Description

The enclosed pressure sensor contains a temperature-compensated differential-pressure sensor, a function selector switch and two equivalent modular connections for bus communication. The pressure transducer is supplied with a hose (2-metres long), through-connector nipples (70 mm) and a cable for communication with the air handling unit. The cable can be 1 or up to 15 metres long depending on the length ordered. The TBLZ-2-13 accessory can be used for lengthening the cable, if needed. The communication cable contains conductors for voltage supply and for signal transmission.

Operation

The pressure transducer is allocated an identity and bus address depending on the position in which the function selector switch is set. The pressure transducer transmits its current value via bus.

Indicating light emitting diodes

- LD1 Indicates with a steady green glow 24 V DC supplied to circuit card.
- LD2 Indicates with a flashing yellow glow that communication is in progress.

2. Installation

Mount the pressure transducer at a suitable location, as described in Sections 2.1 and 2.2.

The pressure transducer's performance is not affected by the location where it is mounted. In consideration of its degree of protection, the pressure transducer shall not be mounted with the pressure connections pointing upward.

Connect the pressure sensor connections to the measurement tapings in the air handling unit/power roof ventilator or on ducts. Notice the plus and the minus symbols on the pressure transducer connections.

The measurement hoses to the pressure transducer must be arranged lower than the transducer itself. If the measurement hoses are arranged higher than the transducer, there is risk of condensate inside the hoses running down into, collecting inside and ruining the pressure transducer.

Open the cover of the pressure transducer by pressing the locking hook inward and lifting it upward. Set the pressure transducer operating mode on the function selector switch (use a

Figure 1

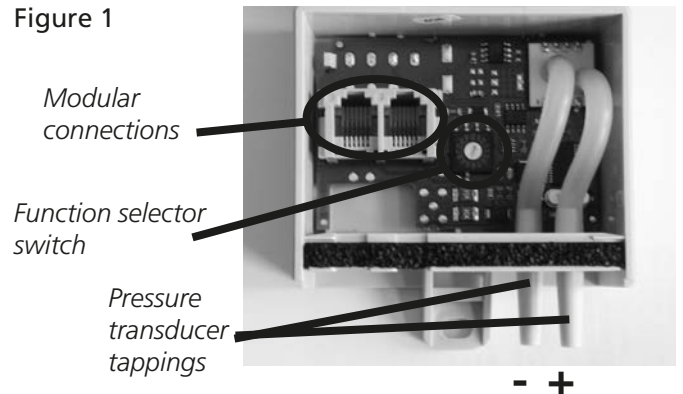

Function selector switch

- | | |
|--|---|
| 0 ReCO ₂ (GOLD) or flow regulation (MIRU Control) | 7 Monitoring the rotary heat exchanger |
| 1 Fan 1 (GOLD/COMPACT) or pressure regulation (MIRU Control) | 8 Supply air prefilter |
| 2 Fan 2 | 9 Extract air prefilter |
| 3 Filter 1 (standard) | A Supply air final filter |
| 4 Filter 2 (standard) | 7 Monitoring the rotary heat exchanger |
| 5 Supply air duct | B Purging airflow through rotary heat exchanger ¹⁾ |
| 6 Extract air duct | C Plate heat exchanger |
| | D - F Spares |

¹⁾ Requires part no. 804937-01

Figure 2

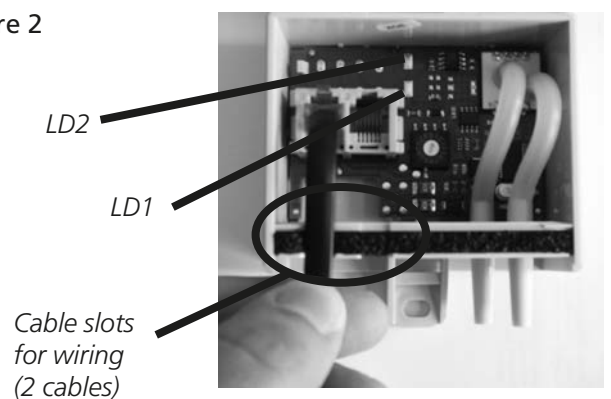

small screwdriver for slotted screws). See Figure 1 and the table to the right!

For the GOLD LP and the COMPACT, connect the pressure sensor to an optional Internal EIA-485 bus contact on the air handling unit's control unit. This should be done by means of the cable supplied.

For the GOLD RX/PX/CX/SD version E/F, connect pressure sensors to optional contacts marked Com 6 – Com 11, however duct pressure sensors for pressure regulation are exceptions and must be connected to optional contacts marked Com 1 – Com 3. This should be done by means of the cable supplied.

It is not important which pressure transducer contact you use. Two contacts are provided for connecting several pressure transducers in a series.

Position the cable to fit into the slot provided in the enclosure, see Figure 2, and close the cover of the pressure transducer.

2.1 Pressure regulation (GOLD/COMPACT/MIRU Control) and flow regulation (MIRU Control)

GOLD/COMPACT

Pressure transducers are normally fitted to air ducts.

The function of a pressure transducer is to measure the pressure differential between the pressure inside the ducting and atmospheric pressure. Connect the hose as shown in Figure 3, depending on the ducting system.

Set the function selector switch on the pressure sensor to position 5 for sensors that measure in the supply air duct, and to position 6 for sensors that measure in the extract air duct.

Set the air handling unit for pressure regulation (See the Section entitled Airflow in the Operation and Maintenance Instructions).

The required pressure setpoint can be set and the current pressure readings can be viewed via the hand-held micro terminal of the air handling unit.

MIRU Control

If flow regulation is used, install the pressure sensor inside the power roof ventilator. Mount it at an appropriate spot in the fan motor space. Connect the tubes to the existing measurement tappings in the same space. Connect the tube from the blue tapping to "minus" on the pressure sensor and connect the tube from the white tapping to "plus" on the pressure sensor.

If pressure regulation is used, install the pressure sensor inside the extract air duct (see Image 3). The pressure sensor should measure the difference in pressure between the pressure of the duct and the atmospheric pressure.

The function selector switch on the pressure sensor should be set to position 0 for flow regulation or to position 1 for pressure regulation.

Set the MIRU Control for flow regulation and/or pressure regulation (see the instructions for installing the MIRU Control, the sections entitled Flow/Pressure and Basic Setting).

The desired flow/pressure setpoint can be set and the current flow/pressure reading can be viewed on the control panel/display screen of the MIRU Control unit.

Figure 3

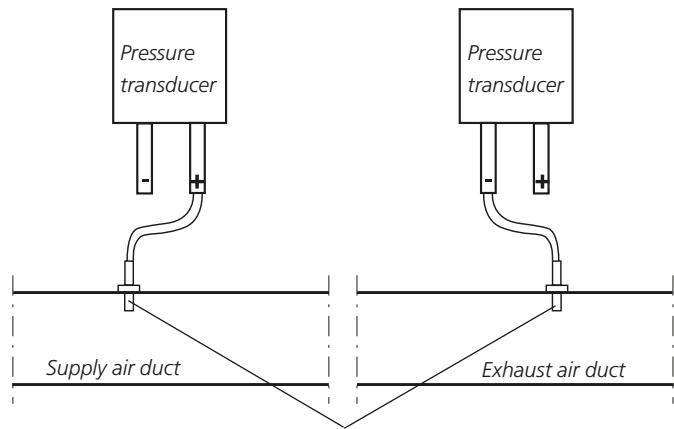

N.B! In some cases you might need to cut the measurement tappings to shorten them. They should not protrude more than 10 mm from the inner wall inside the duct.

2.2 Defrosting function for Rotary heat exchanger

Install the pressure sensor at a suitable location next to the air handling unit's junction hood (GOLD RX/LP sizes 04-08 and COMPACT Unit), inside the heat exchanger section (GOLD, sizes 14-80), on the outside of the heat exchanger section (GOLD size 100-120) or on the top of the air handling unit (COMPACT Top/Air/Heat).

Connect the pressure sensor tapplings to the nipples on the air handling unit that are normally used for adjusting the pressure balance across the heat exchanger. There are no such nipples fitted to the COMPACT Air/Heat units. Mount nipples on these air handling units as illustrated in Figure 7.

Connect the nipple that measures pressure at the extract air fan to the minus (-) terminal of the pressure sensor and the nipple that measures pressure at the filter to the plus (+) terminal. See Figures 4, 5, 6, 7 and 8.

Set the function selector switch on the pressure transducer to position 7.

Set the air handling unit to defrosting (see the Section entitled Heat Exchanger in the Operation and Maintenance Instructions).

In order for the pressure sensor to obtain the correct reference pressure across the heat exchanger, do the calibrating after the installation work is completed. See the Operation and Maintenance Instructions.

Set the desired pressure increase limit (factory setting: 50 Pa) for the defrosting function according to the Section on Alarm Limits in the Operation and Maintenance instructions.

Figure 4a

GOLD RX, sizes 04-08
Supply air fan, right, lower level

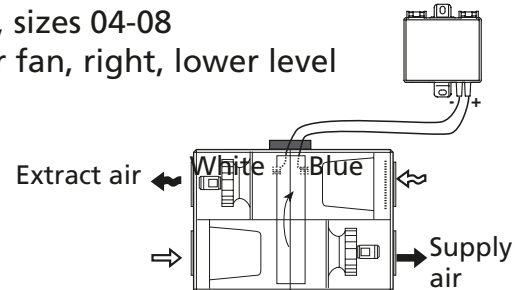

GOLD RX, sizes 04-08
Supply air fan, left, upper level

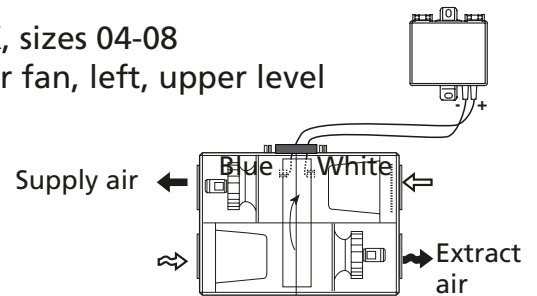
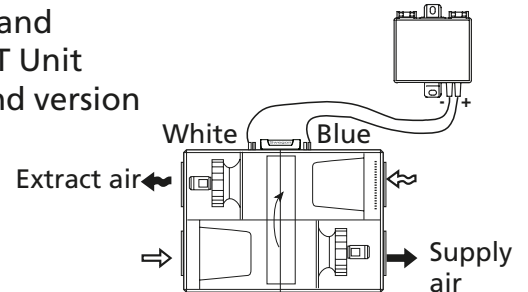

Figure 4b

GOLD LP and
COMPACT Unit
Right-hand version



GOLD LP and
COMPACT Unit
Left-hand version

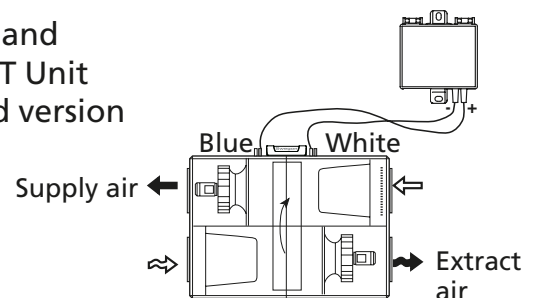
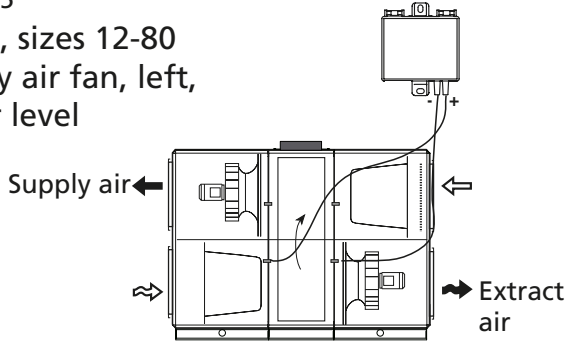

Figure 5
GOLD, sizes 12-80
Supply air fan, left, upper level



GOLD, sizes 12-80
Supply air fan, right, lower level

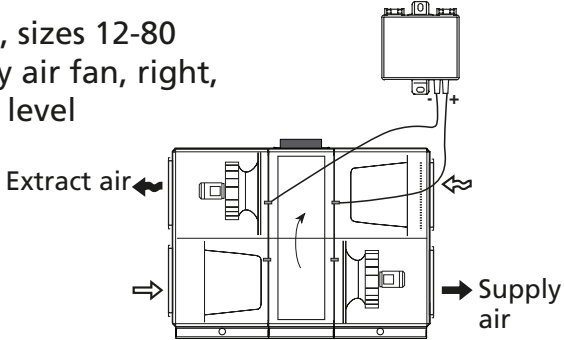
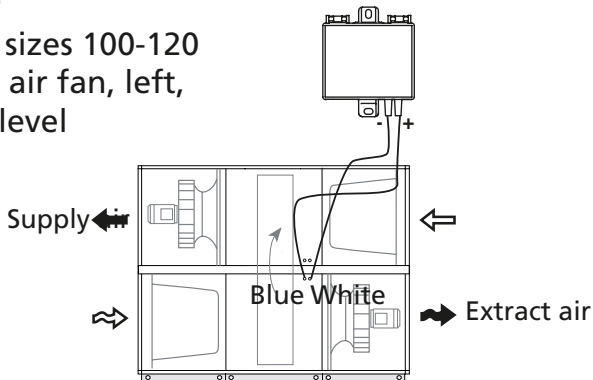

Figure 6
GOLD, sizes 100-120
Supply air fan, left, upper level



GOLD, sizes 100-120
Supply air fan, right, lower level

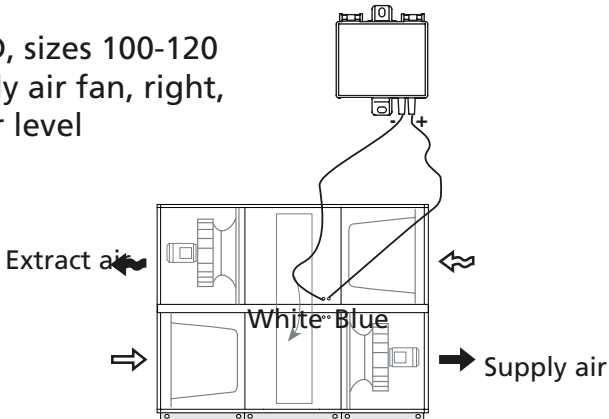

Figure 7
COMPACT Top

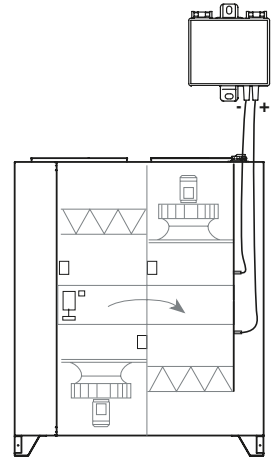
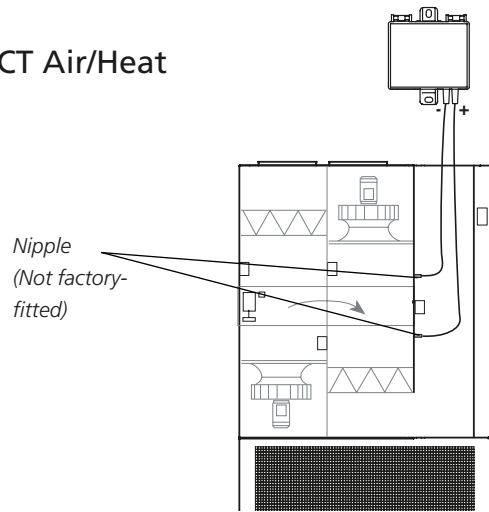

Figure 8
COMPACT Air/Heat



2.3 ReCO2 (GOLD RX/CX only)

The pressure sensor is used to ensure the outdoor air flow during ReCO2 control.

Install the pressure sensor at a suitable location inside (sizes 12-80), or on the outside (size 100-120) the heat exchanger section.

Connect the pressure sensor output to the nipples on the GOLD unit that is normally used for adjusting the pressure balance of the heat exchanger.

Connect minus (-) on the pressure sensor to the nipple that measures pressure at the supply air fan, and plus (+) to the nipple that measures pressure at the filter, see Figures 9 and 10.

Set the pressure sensor's function switch to position 0.
Set the GOLD unit to ReCO2 control, see the Operation and Maintenance Instructions.

In order for the pressure sensor to obtain the correct reference pressure for the heat exchanger, calibrate after installation, see the Operation and Maintenance Instructions.

Figure 9

**GOLD, sizes 12-80
Supply air fan, left,
upper level**

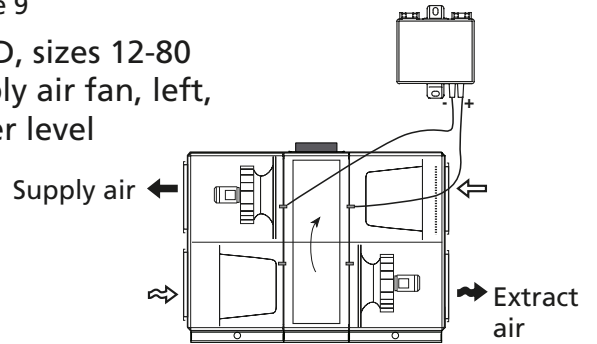

**GOLD, sizes 12-80
Supply air fan, right,
lower level**

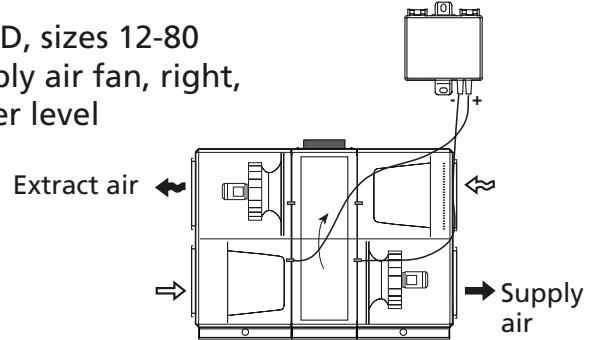
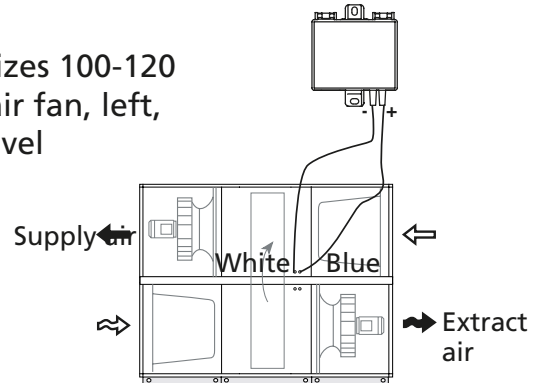
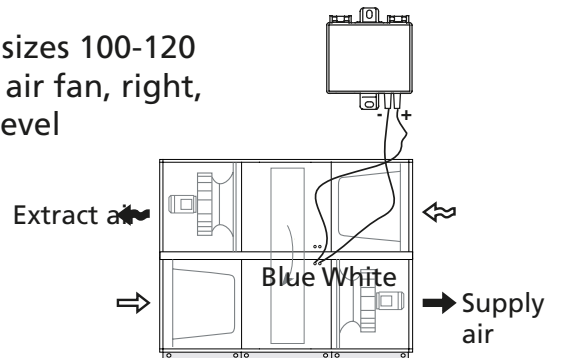

Fig. 10

**GOLD, sizes 100-120
Supply air fan, left,
upper level**



**GOLD, sizes 100-120
Supply air fan, right,
lower level**



2.4 Prefilter (GOLD RX/PX/CX/SD and COMPACT Unit/Top only)

Install the pressure sensor in a suitable location next to the filter or by the GOLD unit's connection head.

The pressure sensor measures the pressure drop of the filter, connect hoses according to image 11.

Set the pressure sensor's function switch to position 8 for prefilter supply air, and to position 9 for prefilter extract air.

Set the unit to prefilter monitoring, See the Operation and Maintenance Instructions.

Set the desired pressure drop increase (factory setting: 00 Pa) according to the Operation and Maintenance instructions.

Figure 11

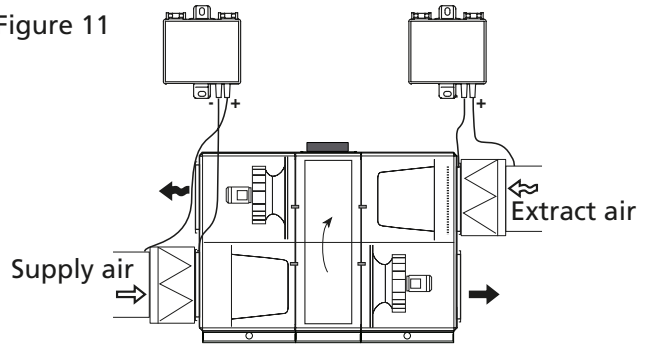

The diagram shows both the extract and supply air prefilters. Prefilter can also be used only for supply air or extract air.

2.5 Standard filter (GOLD LP and COMPACT only)

COMPACT

Install the TBLZ-1-23 pressure sensor next to the ordinary pressure sensor of the air handling unit. See Figure 12.

Drill the holes for the measurement tapplings, see drawing. N.B.! The measurement tapping downstream of the filter (seen in the direction of airflow) must not block the space provided for opening the filter locking mechanism. Fit the measurement tapplings.

Connect the tube from the measurement tapping upstream of the filter (viewed in direction of airflow) to the plus connection on the pressure sensor and connect the tube from the measurement tapping downstream of the filter to the minus connection on the pressure sensor.

To view the position on function selector switch of the pressure sensor. See Figure 14.

Connect the communication cable between the TBLZ-1-23 pressure sensor and the ordinary pressure sensor of the air handling unit to optional modular connections.

Set the air handling unit for filter monitoring with pressure sensor, see the Operation and Maintenance Instructions.

Set the desired pressure drop increase before alarm (factory preset to 100 Pa) according to the Operation and Maintenance instructions.

GOLD LP

Install the TBLZ-1-23 pressure sensor next to the ordinary pressure sensor of the air handling unit. See Figure 13.

Drill the holes for the measurement tapplings, see drawing. Drill the hole for the measurement tapping upstream of the filter (viewed in direction of airflow) in the duct or accessory. Fit the measurement tapplings.

Connect the tube from the measurement tapping upstream of the filter (viewed in direction of airflow) to the plus connection on the pressure sensor and connect the tube from the measurement tapping downstream of the filter to the minus connection on the pressure sensor.

To view the position on function selector switch of the pressure sensor, see Figure 14.

Connect the communication cable between the TBLZ-1-23 pressure sensor and the ordinary pressure sensor of the air handling unit to optional modular connections.

Set the air handling unit for filter monitoring with pressure sensor. See the Operation and Maintenance Instructions.

Set the desired pressure drop increase before alarm (factory preset to 100 Pa) according to the Operation and Maintenance instructions.

Figure 12, COMPACT (all)

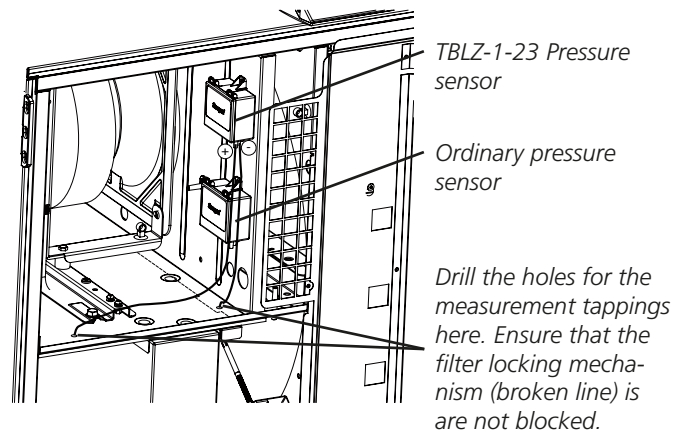

Figure 13, GOLD LP

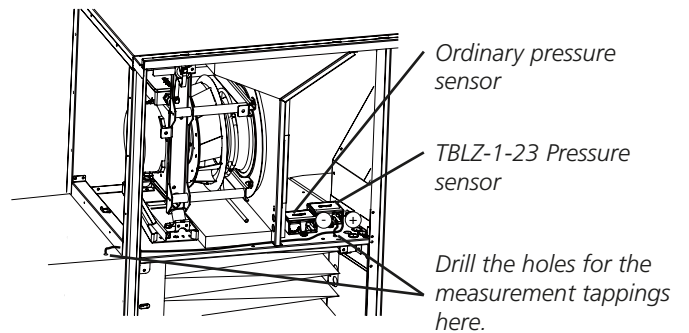
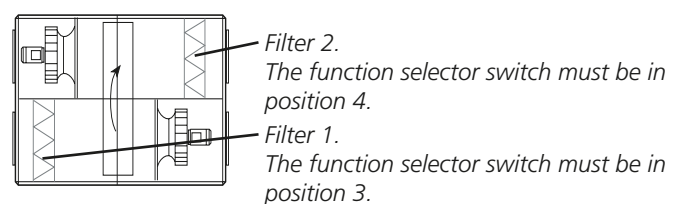
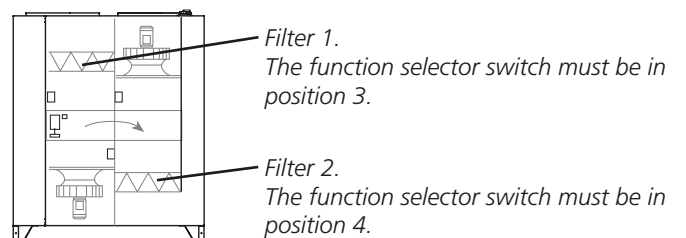

Figure 14, COMPACT and GOLD LP
Air handling unit shown from the inspection side

COMPACT Unit and GOLD LP



COMPACT Top



COMPACT Air/Heat

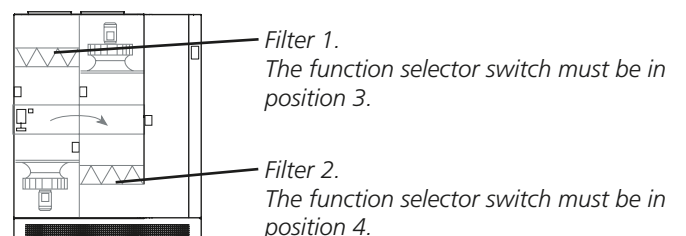

3. Data

Terminal contacts:	2 x RJ 12 6/6
Voltage supply (Via modular contact):	24V DC
Ambient temp. in storage	-50 °C — 70 °C, 10 — 95 % RH
Ambient temp. Normal:	-20 °C — 50 °C, 10 — 95 % RH
Measuring range	0 — 2000 Pa ¹⁾ , -1000 — + 1000 Pa ²⁾
Measuring accuracy	0.5% x measured value + 2.5 Pa
Linearity:	< +/- 1% full scale
Degree of protection:	IP 54 to EN 60529
CE approval:	EN 61000-6-2, EN 61000-6-3

¹⁾Part. no. 802984-01

²⁾Part. no. 804937-01

Dimensions

